

CONTENTS

GENERAL INFORMATION.....	1
AUTO-ID COMMUNICATION EXPO PLOFILE	2
BOOTH SIZE AND CHARGES “Type A”	3
BOOTH SIZE AND CHARGES “Type B (Low-priced, Small size)”	4
Mobile & Wearable Zone.....	5
Imaging Zone	6
Sensor Network Zone.....	6
HOW TO EXHIBIT	7
OFFICIAL ADVERTISEMENTS	8
ADMINISTRATION.....	9
REPORT OF LAST EXHIBITION	10
MOVE-IN AND MOVE-OUT	11
DECORATION.....	12
FIRE PREVENTION.....	12
ELECTRICITY.....	13
WATER & COMPRESSED AIR.....	14
TELEPHONE	15
INTERNET	15
HOTEL.....	15

AUTOID & COMMUNICATION EXPO 2017

~ ID First ~

GENERAL INFORMATION

Title	AUTOID & COMMUNICATION EXPO 2017
Show Period	September 13 (Wed) - 15 (Fri) , 2016 10:00 - 17:00
Venue	TOKYO BIG SIGHT(Tokyo International Exhibition Center), East Hall 3-10-1, Ariake, Koto-ku, Tokyo 135-0065 Japan Tel: +81-3-5530-1111
Admission Fee	¥1,000 (Free entrance for visitors with invitation tickets.)
Sponsor	Japan Automatic Identification Systems Association FK Bldg.7F, 1-9-5, Iwamoto-cho, Chiyoda-ku, Tokyo 101-0032, Japan Tel:+81-3-5825-6651 Fax:+81-3-5825-6653 http://www.jaisa.or.jp
Supporting Organizations (Planned)	Ministry of Internal Affairs and Communications Ministry of Economy, Trade and Industry and others
Special Cooperation	Fuji Sankei business i.
Cooperating Organization	Approx.30 relevant organizations
Special Exhibit Zone	Mobile & Wearable Zone An exhibit zone for Mobile and Wearable Devices. Imaging Zone An exhibit zone Featuring State-of-the-Art Applications of Image Identification Technology Sensor Network Zone An exhibit zone Featuring Sensors and Network Construction Services
Concurrent Programs	AUTO-ID Seminar, Business & Technology SPICE (Japanese only) September 13 (Wed) - 15 (Fri)
Reception	Opening Ceremony (In front of registration counter) September 13 (Wed) 9:40~ Celebratory Reception September 13 (Wed) 17:30~
Show Office	CNT Inc. Attn: (Mr.) Y. Yoshida 4F, 1-24-3 Kanda Suda-cho, Chiyoda-ku, Tokyo 101-0041, Japan Tel: +81-3-5297-8855 Fax: +81-3-5294-0909 E-mail: info_en@autoid-expo.com

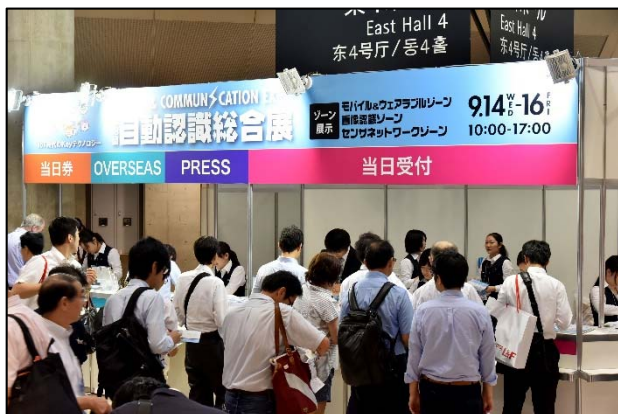

AUTO-ID COMMUNICATION EXPO PLOFILE

The only exhibition in Japan devoted exclusively to cutting-edge automatic identification products, technologies, and solutions.

Exhibit Categories

- Automatic identification products and technologies
Bar codes and Two-dimensional symbols, GS1 DataBar, RFID, NFC, Cards (IC, magnetic, optical, etc.), OCR, Biometrics, Image recognition
- Solutions using automatic identification
All solutions that take advantage of automatic identification, such as production support systems, distribution and logistics systems, retail and wholesale support systems, traceability, Supply Chain Management (SCM), event and amusement support systems, Customer Relationship Management (CRM), security systems, medical, education, library, transportation (rail, air, harbor, etc.), finance, disaster control, other public service support systems
- Middleware platform, encryption technologies, image processing

Zone Dedicated to Automatic Identification Technology, a Must in the IoT!

- Mobile & Wearable Zone
This zone features mobile terminals, mobile-connected devices, wearables, and the like.
- Imaging Zone
This zone features imaging, the ultimate in automatic identification technology – including individual pattern identification using image identification technology (image processing, 3D measurement), barcode identification using image processing, and character recognition (OCR).
- Sensor Network Zone
This zone features various sensors and Network Construction Services Zone—Key Technologies for the IoT and AI That Link Systems with Information from Objects

A merit to exhibit this Trade Show!

- Automatic identification solutions can be offered to users.
Many users from industries such as manufacturing, distribution, logistics, retailing, and public services will attend this exhibition seeking efficient, safe, and reliable automatic identification solutions.
- Many system integrators and vendors will attend, seeking cutting-edge equipment and technologies.
Because many system integrators and related vendors will attend this exhibition, it will be a great opportunity to expand your business and sales channels.
- The exhibition will be a place for integration and collaboration with automatic identification related businesses.
This exhibition will be a great opportunity for collaboration between businesses and the acquisition of business partners, as cutting-edge equipment and products, solutions, and services related to automatic identification will be exhibited under the same roof, and many system integrators and vendors will be attending



BOOTH SIZE AND CHARGES “Type A”

Minimum booth Unit (size) : 3.0m(W)×3.0m(D)×2.7m(H)

Participation fee per minimum booth unit :

Number of booths	Exhibition Fee (Cost per booth including consumption tax)	
	JAISA members	Non-members
1 to 2 booths	421,200 yen	475,200 yen
3 to 7 booths	378,000 yen	432,000 yen
8 to 12 booths	334,800 yen	388,800 yen
13 to 15 booths	324,000 yen	378,000 yen
16 to 24 booths	313,200 yen	367,200 yen
25 booths or more	291,600 yen	345,600 yen

(JPY, Consumption tax included)

The exhibition fees include: exhibition space -- width: 3.0 m × depth 3.0 m -- walls

Explanation of Booth Layout

Layout of booths is to be chosen from alternatives shown on the below.

- Minimum 4 units of booth are required to form “Block” type layout.
- Minimum 8 units of booth are required to form “Island” type layout.
- The maximum number of booth allowed to form “Row” type layout is 5

1 to 5 booths in a Row type

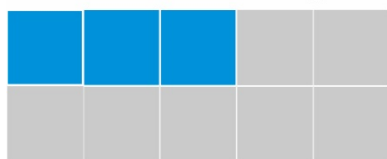

4 block type booths

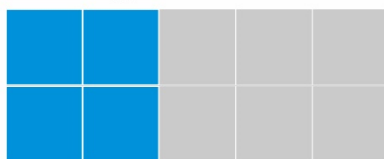

8 Island type booths

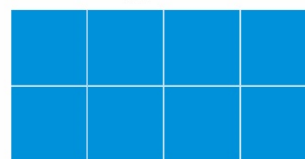

On height restrictions for decorations

*Row type booth(s)

*Block type booth(s)

Decorations are permitted to a maximum height of 2.7 m for areas within 1 m of adjacent booths, rear walls and access aisles, while the maximum height for any areas other than these is 3.6m.

*Row type booth(s)

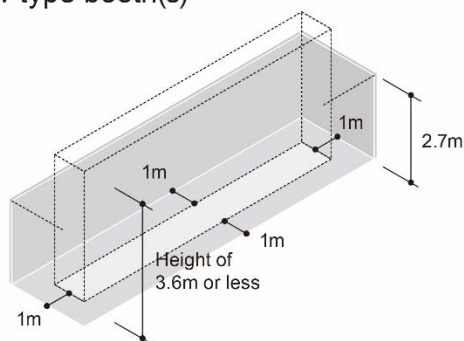

*Block type booth(s)

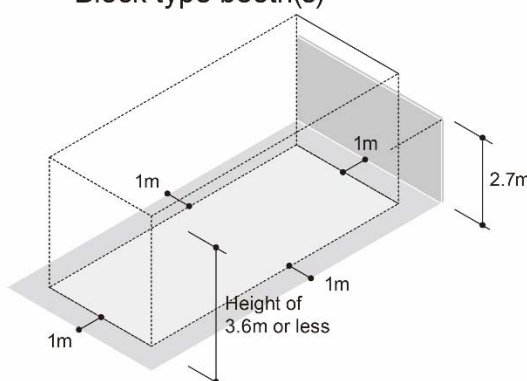

*” Island” type booth(s)

Decoration is permitted up to a maximum height of 5.0m.

BOOTH SIZE AND CHARGES “Type B (Low-priced, Small size)”

Minimum booth Unit (size) : 2.0m(W)×2.0m(D)×2.7m(H)

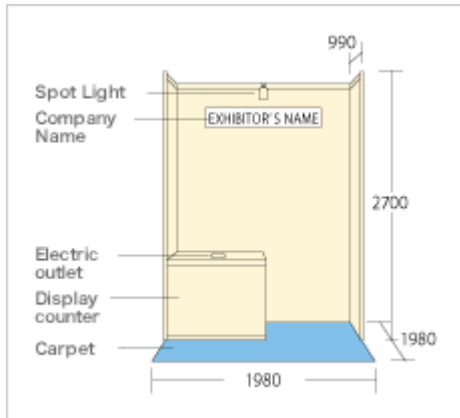

Participation fee per minimum booth unit :

Number of booth	Exhibition Fee (Cost per booth including consumption tax)	
	JAISA Members:	Non-JAISA Members:
1 to 2 booths	226,800 yen	259,200 yen

The exhibition fees include:

exhibition space -- width: 2.0 m × depth 2.0 m -- walls (rear and side, 1 m); company nameplate; carpet;
 exhibition stand--width: 1.0 m × depth 1.0 m × height: 0.8 m -- spotlight: 100W × 1; electrical outlets (100V with ground) —one set of two outlets; installation costs for electrical lines up to 500W; electricity costs.

* Additional charges apply for requests of additional equipment. Detailed materials will be distributed at the orientation for exhibitors.

* Please be aware that even when the basic display mentioned above is not used, deductions from the exhibition fee cannot be made.

On height restrictions for decorations

The maximum standard height is 2.7 m.

Exhibition conditions

- Up to two booths per company
- Cannot be exhibited together with Type A exhibition specifications
- Presentations using equipment such as microphones and speakers cannot be given in the booths.
- The locations of the booths are not determined by lottery, but rather at the discretion of the host.

Mobile & Wearable Zone

An exhibit zone Features mobile terminals, mobile-connected devices, wearables, and the like.

These days, it is no longer unusual to find mobile terminals in manufacturing, transportation, logistics, retail, and other sites. What's more, much attention has been focused recently on wearable devices worn to improve the efficiency of work.

The AUTO-ID & COMMUNICATION EXPO has introduced a zone dedicated to mobile terminals, mobile-connected devices, wearables, and the like.

Please consider exhibiting in the "Mobile & Wearable Zone" this year.



Exhibit Categories

- **Mobile devices/accessories**
Readers/writers, printers, business PDAs, POS, tablets, smartphones, medical devices, etc.
- **Wearable devices**
Glasses, watches, rings, etc.
- **Software/apps**
ales support software/apps, inventory management software/apps, sales management software/apps, manufacturing process management software/apps, other support software/apps, etc.
- **Embedded devices, middleware, transmission-related services**

Exhibition fees and exhibition unit specifications

Applied in accordance with type A or type B of the AUTOID & COMMUNICATION Expo.

Imaging Zone

An exhibit zone Featuring State-of-the-Art Applications of Image Recognition Technology

With the rapid spread of cell phones and smartphones with cameras, it is no exaggeration to say that we're now living in an era when everyone owns and uses their own personal image identification tool. And these tools have still further potential, not just for expanded use in manufacturing processes and security applications, but also for more personal use in everyday life, access to information, and the like.

This zone brings together various examples of advanced image identification technology including applied technologies for corporate and personal use, with a focus on individual pattern identification using image identification technology (image processing, 3D measurement); image information identification by image processing and barcode identification; character recognition (OCR); fingerprint and face authentication; and so forth.

Exhibit Categories

- **Image input devices**
Various cameras, image input boards, lighting equipment for image input, and more
- **Image processing devices**
Various image processing devices, image analysis systems, image processing boards, and more
- **Software**
Inspection software, measurement software, analysis software, barcode reading software, and more
- **Systems**
Face/fingerprint authentication systems, next-generation OCR systems (character recognition), augmented reality (AR) systems, abnormal behavior detection systems, and more

Exhibition fees and exhibition unit specifications

Applied in accordance with type A or type B of the AUTOID & COMMUNICATION Expo.

Sensor Network Zone

An exhibit zone Featuring Sensors and Network Construction Services Zone —Key Technologies for the IoT and AI That Link Systems with Information from Objects

More and more attention is being focused on the IoT, which manages various “things” such as manufacturing equipment, precision instruments, construction equipment, electrical and electronic parts, home electronics, A/V equipment, and cars through recognition with identification technology (RFID, NFC, etc.), and linking them to the Internet, and sensor networks such as Machine to Machine (M2M) systems connected by inter-device networks. Information obtained through these technologies is also beginning to create new value through its application in the fields of artificial intelligence (AI) and deep learning.

This zone will bring together examples of various sensors, devices, and network construction services connected by automatic identification technology, such as sensor technology, cloud development, and data application and analysis.

Exhibit Categories

- **Devices and products**
Media equipped with sensor functions such as ZigBee, RFID, and NFC and devices such as PDAs for business use, tablet devices, smartphones, readers/writers, terminal modules, and more
- **Middleware and platforms**
Cloud development services, M2M business systems, IoT business systems, automation tools, infrastructure equipment, and more

Exhibition fees and exhibition unit specifications

Applied in accordance with type A or type B of the AUTOID & COMMUNICATION Expo.

HOW TO EXHIBIT

Application

Please fill in the attached “application form for exhibit” and send it to the Show Office.

Application Deadline

May 26, 2017

(The application will be closed as soon as all the booths are booked.)

Booth assignment

The booth assignment will be decided by open lot at exhibitor’s explanatory meeting on middle of July. If it is impossible to attend the meeting, the organizer draws lots instead of them.

Payment

On receipt of the application form, invoice will be issued by the Show Office.

Please make remittance in Japanese Yen to the designated bank account by July 31 (Mon.), 2017.

Cancellation

As a principle, no cancellation is accepted. The organizer, however, may accept the cancellation if there should be right reason to accept with the following cancellation fee.

May 26 - June 30, 2017 : 80% participation fee
 After June 31, 2017 : 100% participation fee

Schedule

May 26, 2017 (Fri)	Application for AUTOID & COMMUNICATION EXPO Deadline
July 12, 2017(Wed)	Exhibitor’s explanatory meeting, Booth assignment open lot(in Tokyo)
July 31, 2017(Mon)	Remittance deadline
Middle of August	Sending of the Exhibiter badge & Invitation Tickets
September 11 &12, 2017	Move-in / Set-up day
September 15, 2017	Move-out / Dismantle day

OFFICIAL ADVERTISEMENTS

Advertisements on the Official Site

We will post the AUTOID Communication Expo official website from the end of February to the end of October. A wealth of information is posted at the official website, including detailed information on the Expo and exhibit information from exhibitors, as well as numerous speeches every year from relevant people in the industry.

Please use the following advertising plan, which is set for the official site from this year going forward. The plan provides the opportunity for you to effectively promote your company prior to the time of the Expo in order to draw visitors to your booth.

You can run banner advertisements and menu bar advertisements at the official homepage for the 19th AUTOID Communication Expo.

《Requirements for Application》

■Deadline for Application: 31 July (Mon) 2017

* The application period ends if all time slots are filled

		① Header banner	② Menu bar
Image Size		100 pixels (height) × 200 pixels (length)	40 pixels (height) × 150 pixels (length)
File Format	GIF	○	○
	Animated GIF	○	○
	FLASH	○	×
Fee for Posting / per month(with tax)		43,200 yen	21,600 yen
Number of Applications		3	4
Term of Posting		Scheduled for: 1 March 2016—31 October 2016	



E-Mail News with Five-Column Ads

At AUTOID COMMUNICATION Expo, E-Mail News bulletins are scheduled to be sent multiple times to the mailing list (approximately 90,000 past Expo visitors.)

《Requirements for Application》

■Deadline for application: Please refer to the figure to the below

* The application period ends if all time slots are filled.

■Number of Applications: One for each mail.

■Method of Submission: As data

■Size of Draft: Body text (70 characters x five lines)

■Fee for posting: 32,400 yen (with tax)

Time frame	Topics	Time to send	Deadline for applications
-	Prior Registration Begins	Beginning of April	-
①	Seminar Overview Posted	Beginning of August	June 20
②	Latest Information Posted	Middle of August	August 4
③	Warmly Welcoming Seminars	End of August	August 4
④	Opening Next Week!	September 5	August 4
⑤	Seminar Deadline Tomorrow	September 7	August 4
⑥	Opening Tomorrow	September 12	August 4
⑦	Held until Tomorrow	September 14	August 4

ADMINISTRATION

The following facilities will be provided at the show site for the convenience of exhibitors and visitors as well as for the management of the show.

Secretariat Office The Secretariat office will be set up at the show site from 8:00 , September 11 (Mon) to 22:00, September 15 (Fri).

TOKYO BIG SIGHT(Tokyo International Exhibition Center), East Hall
3-10-1, Koto-ku, Ariake, Tokyo 135-0063 Japan
Secretariat of 「AUTOID & COMMUNICATION EXPO 2017」

Registration Counter

The Registration Counter will be set up in front of the exhibition site, where visitor registration and information service will be rendered.

Lounge

Lounge will be provided inside the exhibition site as a space for exhibitors to have business talks with visitors.

Prepaid card for Restaurants

Prepaid card system is available at the exhibition site. Instead of cash payment, you can use the prepaid card at the restaurants. The prepaid card is sold at the 「Service corner」at TOKYO BIG SIGHT Entrance Hall.

Facilities of the Exhibition Hall

East 6 Hall (Plan)

Floor space	: 8,670 m ²
Hall Illuminance	: 500 lux
Ceiling height	: 12m
Air-conditioning	: Available
Floor load	: 5t/m ²
Cargo entrance	: H6.0m×W8.0m
Meeting rooms	: We will set up inside the exhibition Hall
Restaurants and shops	: About 20 shops

REPORT OF LAST EXHIBITION

AUTO-ID EXPO 2015

Show Period :	September 14 (Wed.)- 16 (Fri.), 2015 10:00-17:00
Venue :	TOKYO BIG SIGHT(Tokyo International Exhibition Center) East 4 Hall
Number of Exhibitors and Booths :	105 corporations and 3 organizations, at 272 booths
Total Number of Visitors :	27,766 (Include visit from concurrent events)
Admission Fee :	¥1,000
Sponsor :	Japan Automatic Identification Systems Association (JAISA)
Supporting Organizations :	Ministry of Internal Affairs and Communication Ministry of Foreign Affairs Ministry of Economy, Trade and Industry
Special Cooperation :	Fuji Sankei business i.
Cooperating Organization :	Approx.34 relevant organizations
Seminar :	AUID-ID Seminar, Business & Technology SPICE September 14 (Wed.) - 16 (Fri.), Conference Room (Tower Building 6F)

Exhibitors List 2016

AUTOID & COMMUNICATION EXPO

AIDCTI / TEKLYNX INTERNATIONAL , AINIX Corp. ,ALF INC. , ALTECH CO., LTD. , A-POS Co., Ltd. , Aperza Inc. AUTOMATION NEWS , Autonics Co., LTD. , BLUEBIRD Inc. , BROTHER SALES, LTD. , CLI., INC , DAIDO CORP. , DENSO WAVE INC. , DM CARD JAPAN CO., LTD. , Duplo Co., Ltd. , EFTECT [Tokai Denki Co., Ltd.] , E-garde Co., LTD. , EIZOJOHO INDUSTRIAL , Elite Co., Ltd. , FUJISANKEI BUSINESS I. , FUJITSU LTD. / FUJITSU FRONTTECH LTD. , GICHO BUSINESS COMMUNICATIONS CO., LTD. , HAYATO INFORMATION CO., LTD. , Imager CO., LTD. / I.M. Project CO., LTD. , INCOM CO.,LTD. , IT Doraku Institute, Co., Ltd. / Terrara Code Research Institute, Inc. , JAPAN EDITORIAL & PUBLICATION CO., LTD. , JAPAN INDUSTRIAL PUBLISHING CO., LTD. , JAPAN PACKAGING INSTITUTE , JAPANESE STANDARDS ASSOCIATION , JNC CORP. / SMART Corp., Ltd. , KOATSU GAS KOGYO CO., LTD. , LAPIS Semiconductor Co., Ltd. , MARS TOHKEN SOLUTION CO. LTD. / MARS WINTEC CO. LTD. , MASPRO DENKOH CORP. , Microwave Absorbers Inc. , MIKI-BYORA Screws CO., LTD. , Mitsunami Co., Ltd. , MIYAKAWA ELECTRIC WORKS LTD. , M-RF CO., LTD. , Murata Manufacturing Co., Ltd. , NATEC Inc. , NiGK Corp. , NIKKEI INC. , NIPPON STEEL & SUMIKIN BUSSAN CORP. / Impinj, Inc. , NISICOM SOLUTIONS INC. , Nissei Ltd. , NITTA CORP. , NOZAKI INSATSU SHIGYO CO., LTD. , Okabe Marking Systems Co., Ltd. , OPTO ELECTRONICS CO., LTD. , PHOENIX CO., LTD. , RFID Alliance Corp. / Alien Technology LLC , RICOH JAPAN Corp. / Ricoh Co., Ltd. , Rozetta Corp. , RYUKEN CO., LTD. , RYUTU JOHO RABERUSHA , SAG JAPAN CO., LTD. , SATO HOLDINGS CORP. , SCSpro JPN CO., LTD. , SEALEX CORP. , SECURITY SANGYO SHIMBUN, INC. , Sharp Business Solutions Corp. , Shin-Norinsha Co., Ltd. , SilenceNet, Inc. , SML GROUP , TAKAYA Corp. , TEIJIN LTD. , TENTAC CO., LTD. , Terrara Code Research Institute, Inc. , THE DISTRIBUTION SYSTEMS RESEARCH INSTITUTE , TOPPAN PRINTING CO., LTD. , TOSCO CORP. , TOSHIBA TEC CORP. , UPR Corp. , Welcat Inc. , Winso Technology Ltd., Co. , Yoshikawa RF Semicon Co., Ltd.

Mobile & Wearable Zone

AIMEX Corp. , Imager CO., LTD. / I.M. Project CO., LTD. , Infinitegra, Inc. , OPTO ELECTRONICS CO., LTD. , RIOTEC CO., LTD. , Sheng Hero Corp. , Welcat Inc. , WELCOM DESIGN K.K. / CipherLab Co., Ltd.

Imaging Zone

BRAIN CO., LTD. , Canon IT Solutions Inc. , DAITO ELECTRON CO., LTD. , Duplo Co., Ltd. , FUJIFILM Imaging Systems Co., Ltd. , GRAPE SYSTEMS INC. , KYODO PRINTING CO., LTD. , LinX Corp. , Prolinx Corp. , TOME R&D Inc. , Top Image Systems Japan Ltd. , Trust Components Co., Ltd. , Trust Technology Co., Ltd.

Sensor Network Zone

ICOP I.T.G. Inc. , KAIZAR Corp. , KYUSHU TEN LTD.

MOVE-IN AND MOVE-OUT

1) Move-in / Set-up	September 11 (Mon)	9:00 - 18:00
	September 12 (Tue)	9:00 - 18:00

2) Overtime Charge

Every exhibitor who operates except for the hours as specified in above (1) will be billed according to the following overtime charge. Exhibitors exceed the hours specified above will be asked ¥10,800 for each extra hour.

*No overtime charge for move-out period.

3) Move-out / Dismantle September 15 (Fri) 17:00 - 22:00

A certificate will be issued to all vehicles carrying facility equipment out of the hall.

The procedure will be taken place at the appointed location after 9:00 on September 15.

The vehicle with this certificate should line up there by 17:00, until the move-out operation begins.

4) Move in & out during Show Period

Move-out and move-in is not permitted while the show is open. Approval from the secretariat is required to move in and move out during the show period.

5) Insurance

It is strongly recommended to carry insurance on exhibits, etc. for the whole show period including move-in and move-out.

6) Contractor Badge

Every contractor is required to wear Contractor Badge. Without this badge, none is accessible to the exhibition hall. Three (3) badges per booth will be sent.

7) Exhibitor Badge

Every exhibitor is required to wear Exhibitor Badge. Three (3) badges per booth will be sent.

Exhibitors can take this badge at registration counter in front of the site.

8) Invitation cards

Invitation cards will be sent at the middle of August.

Package Information

Please be sure that packages should reach at the exhibition site on and after September 11. The package has to include the following information.

- | |
|---|
| <p>① Hall Name
TOKYO BIG SIGHT East Hall 6</p> <p>② Address
3-10-1 Ariake, Koto-ku, Tokyo 135-0063 Japan</p> <p>③ Show Name
AUTOID & COMMUNICATION EXPO 2017</p> <p>④ Your company name and the booth number</p> <p>⑤ Name of person in charge</p> <p>⑥ Phone number</p> |
|---|

DECORATION

Exhibits and decorations should be contained within the booth space.

It is prohibited to drill or paint the hall floor. Due to under consideration of fire prevention, ceiling of booths shall not be blocked up with any materials.

The height of decoration

The height of decoration must be lower than 2.7m.

Type A Only

*Company name board can decorate for up to 3.6m in case 1m set back.

*However, decoration for the island booths is permitted to the maximum height of 5.0m.

Official Contractor for Basic Booth Construction

AD POINT CO., LTD.

Attn: Mr. Suzuki

Iwami Bldg., 4-2-1 Iidabashi, Chiyoda-ku, Tokyo 102-0072, Japan

Tel: +81-3-3261-1060 Fax: +81-3-3261-5345

Package Decoration

Ready-to-Move –in Display Package is a basic, convenient and very economical way to exhibit. We provide a Package Decoration and Optional Items which is convenient to display your booth.

Please refer to the application form 「Package Decoration」.

Rental Furniture

Please refer to the application form 「Rental Furniture」.

Anchor Bolt

Anchor bolt can be used with charges (¥1,500 per piece). For order, please complete and submit the attached form to the secretariat by August 4.

Type B

Booth Size: 2mW × 2mD × 2.7mH

Fee Includes following Items:

- One booth for exhibition
- Basic facility
 - walls (rear and side, 1 m); company nameplate; carpet;
 - exhibition stand—width: 1.0 m × depth 1.0 m × height: 0.8 m,
 - spotlight: 100W × 1; electrical outlets (100V with ground),
 - installation costs for electrical lines up to 500W;

FIRE PREVENTION

Smoking is strictly prohibited at booth.

Exhibitors who will use fire or bring hazardous articles (i.e. petroleum, propane gas, etc.) in the exhibition hall, are required to submit the attached form to the secretariat by August 4.

ELECTRICITY

The cost of primary wiring for supply of electricity to each booth and for secondary in-booth wiring work should be borne by exhibitors. Electric rates should also be paid by exhibitors.

Electricity Available

LIGHTING	AC, single-phase, 2-line	100V	50Hz(~3.0kW)
	AC, single-phase, 3-line	100/200V	50Hz(3.1kW~)
POWER	AC, three-phase, 3-line	200V	50Hz
OTHERS	AC, single-phase, 2-line	200V	50Hz

Application for Supply

All exhibitor are required to fill in form and return it to the show management office by August 4 Those who apply later than this deadline may not have electric supply available.

Please indicate in the form the position of an electric outlet, considering the final layout of equipment, and also the connection diagram with load capacity. For a nighttime electric supply, please provide an exclusive circuit intended for this purpose. The capacity for fluorescent lamps and high-pressure mercury lamps should be calculated as 150% of the rating value.

Primary Wiring

The secretariat at the event site will conduct a primary wiring work for supply of electricity to each booth, and provide a switch at the position of an outlet indicated in the form. Unless otherwise specified, the switch will be provided on the back wall at 1m above the floor line. (As a principle, one electrical outlet is provided for exhibitor with two booths.)

Wiring Cost: ¥9,720 per 1kW requested.

*Additional cost will be required for the secondary in-booth works.

Secondary Wiring

In-booth wiring work for lights, power, etc. which is approved by the secretariat should be done by exhibitors themselves and at their own cost.

Electric Rates

The secretariat will charge exhibitors with the electric rates on the following basis.

Electric Rates: ¥1,188 per 1kW requested.

Period for Supply	September 12 (Tue)	12:00-17:00
	September 13 (Wed)	9:00-17:30
	September 14 (Thu)	9:00-17:30
	September 15 (Fri)	9:00-17:00

*Exhibitors who need electric supply at any other time for the purpose of machine assembly, operation adjustment, etc. should contact the secretariat in advance.

Nighttime Supply

An exclusive circuit must be provided for nighttime electric supply, and the distribution board must be so indicated in Japanese. All circuits except the nighttime supply circuit must be cut off at the closing of the show each day. Nighttime supply must be reported to the secretariat in advance.

Requirements for Secondary Wiring Work

Exhibitors may designate any contractor for in-booth wiring and electrical work, however such contractor must be registered at the appropriate governmental office. Any person who performs electric installations must carry an Electrical Contractor's Certificate that conforms to the electrical contract law. Non-qualified persons or those without the certification are not allowed to work. Electrical appliances that come under the Electrical Appliance Handling Regulations must bear the mark of approval by the Ministry of International Trade and Industry.

Every possible care must be taken to prevent fire, accidents, damage to the property. Electrical works during the exhibition period are strictly prohibited. Inspection will be made to check whether the electrical works rendered meet the legal requirements. Any work which turns out to be unsatisfactory must be modified in an appropriate manner as soon as possible, and such modification must be reported to the secretariat.

Protection Devices

The secretariat will assume no responsibility for any damage to exhibits, demonstration goods, equipment, and any other property caused by abnormal power supply, power failure, malfunctions or reduced voltage. Exhibitors should provide protection and precaution devices against any possible accidents.

Maintenance

Professional staff for electrical maintenance will be stationed at the secretariat office during the exhibition period. Any small electrical accidents must be reported to the secretariat.

Official Contractor

IIDA DENKI KOGYO CO., LTD.

Attn: Mr. Hasegawa

1-8-21, shinkiba, Koto-ku, Tokyo 136-0082 Japan

Tel: +81-3-3521-3522 Fax:+81-3-3521-3524

WATER & COMPRESSED AIR

Work and Cost

Upon request, the primary work for supply of water and compressed air to each booth will be done by the secretariat but the cost will be charged to exhibitors who applied for the supply service.

In-booth secondary works must be done by exhibitors and at their own cost.

Rates for water will be borne by exhibitors.

Exhibitors are requested to make payment after the exhibition period.

Water / Drain

Water will be supplied to booth by a polyvinyl chloride pipe. Additional charges will be incurred for in-booth works. The water pressure is 0.18~0.20Mpa. For any other pressure, an additional work is necessary.

Supply:	13mm ϕ , 20mm ϕ
Drain pipe:	40mm ϕ , 50mm ϕ
Cost:	¥64,800 per connection
	¥ 5,400 for maintenance during show
	¥972/m ³ for water rate

Compressed Air

Compressed air will be supplied to booth by a pressure-resistant hose. The pressure is 0.7Mpa. For any higher pressure, an additional work is required. After-coolers or drying equipment should be prepared by exhibitors.

Hose:	1/2", 3/8", 1/4"
Cost:	¥75,600 per connection
	¥ 5,400 for maintenance during show
	*Extra charges will be incurred for overtime operation.

Official Contractor

ThreeS-Setsubi Kogyo

2-15-4 takinogawa, Kita-ku, Tokyo 114-0023 Japan

Tel: +81-3-5907-2100 Fax:+81-3-5907-2500

TELEPHONE

Upon request, a Rental Telephone can be installed at booth with extra charge.

[1] The period of using: From Wednesday, September 13th, 2017 to Friday, September 15th.

Construction: On Tuesday September 12th.

Removal: After closing of the exhibition.

[2] The dead line of application

By Friday, August 4th

[3] The prices (tax included)

¥32,400 / unit

* The above price includes the installation cost and domestic call charges.

* Overseas phone calls, if any, will be charged after the show.

The details and the application method inform it with an Exhibitors manual.

INTERNET

Upon request, a Rental Telephone can be installed at booth with extra charge.

[1] The period of using: From Wednesday, September 13th, 2017 to Friday, September 15th.

Construction: On Tuesday September 12th.

Removal: After closing of the exhibition.

[2] The dead line of application

By Friday, August 4th

[3] The prices (tax included)

Dedicated B FLETS basic line ¥140,400

*If you need global IP address, please contact us.

[4] The method of payment (credit card)

After receiving the order form, we send you a form "Application / estimate form and invoice" by fax or e-mail. Please fill-out the necessary information and send the form back to us.

Please pay the total fee by credit card. VISA or MASTER card is available.

We are very afraid but we cannot take any other cards.

The details and the application method inform it with an Exhibitors manual.

HOTEL

JTB has been appointed as the official travel agent for the Exhibition and will handle accommodations and tours. We will give you further information about it later.

JTB Global Marketing & Travel Inc.

TEL : +81-3-5796-5442 FAX : +81-3-5495-0685

The details and the application method inform it with an Exhibitors manual.