

# AUTO-ID & COMMUNICATION EXPO 2025

## Show Brochure

2025.9.10<sup>WED</sup> - 12<sup>FRI</sup> TOKYO BIG SIGHT

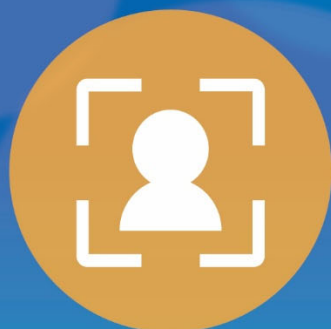

Biometrics



RFID



visual recognition  
system



Bar-code

A BRIGHTER FUTURE WITH AUTO-ID

[www.autoid-expo.com](http://www.autoid-expo.com)

Sponser : Japan Automatic Identification Systems Association



Show Office : CNT Inc.

4F, 1-24-3, Kanda Suda-cho, Chiyoda-ku, Tokyo 101-0041, JAPAN

TEL.+81-3-5297-8855 FAX.+81-3-5294-0909

E-mail : [info\\_en@autoid-expo.com](mailto:info_en@autoid-expo.com)

## CONTENTS

|  |   |
|--|---|
| GENERAL INFORMATION.....                                       | 1 |
| AUTO-ID COMMUNICATION EXPO PLOFILE .....                       | 2 |
| BOOTH SIZE AND CHARGES “Type A” .....                          | 3 |
| BOOTH SIZE AND CHARGES “Type B (Low-priced, Small size)” ..... | 4 |
| Imaging×AI Zone .....  | 5 |
| HOW TO EXHIBIT.....  | 6 |
| OFFICIAL ADVERTISEMENTS .....                                  | 7 |
| ADMINISTRATION.....  | 8 |
| REPORT OF LAST EXHIBITION .....                                | 9 |

# AUTOID & COMMUNICATION EXPO 2025 ~ A BRIGHTER FUTURE WITH AUTO-ID ~

## GENERAL INFORMATION

---

|   |   |
|---|---|
| <b>Title</b>                              | AUTO-ID & COMMUNICATION EXPO 2025   |
| <b>Show Period</b>                        | September 10 (Wed) - 12 (Fri) , 2025 10:00 - 17:00  |
| <b>Venue</b>                              | TOKYO BIG SIGHT(Tokyo International Exhibition Center), West Hall<br>3-11-1, Ariake, Koto-ku, Tokyo 135-0065 Japan<br>Tel: +81-3-5530-1111  |
| <b>Admission Fee</b>                      | FREE (pre-registration required)  |
| <b>Sponsor</b>                            | Japan Automatic Identification Systems Association<br>FK Bldg.7F, 1-9-5, Iwamoto-cho, Chiyoda-ku, Tokyo 101-0032, Japan<br>Tel:+81-3-5825-6651 Fax:+81-3-5825-6653<br><a href="https://www.jaisa.or.jp">https://www.jaisa.or.jp</a> |
| <b>Supporting Organizations (Planned)</b> | Ministry of Internal Affairs and Communications<br>Ministry of Economy, Trade and Industry<br>and others  |
| <b>Special Cooperation</b>                | SANKEI SHIMBUN CO.,LTD.   |
| <b>Cooperating Organization</b>           | Approx.30 relevant organizations  |
| <b>Special Exhibit Zone</b>               | <b>Imaging×AI Zone</b><br>The ultimate automatic recognition technology, image recognition, plus AI, will be presented for cutting-edge applications.   |
| <b>Concurrent Programs</b>                | <b>AUTO-ID Seminar, Business &amp; Technology SPICE</b> (language Japanese only)<br>September 10 (Wed) - 12 (Fri)   |
| <b>Show Office</b>                        | CNT Inc. Attn: (Mr.) M. Tanaka<br>4F, 1-24-3 Kanda Suda-cho, Chiyoda-ku, Tokyo 101-0041, Japan<br>Tel: +81-3-5297-8855 Fax: +81-3-5294-0909<br>E-mail: <a href="mailto:info_en@autoid-expo.com">info_en@autoid-expo.com</a>         |

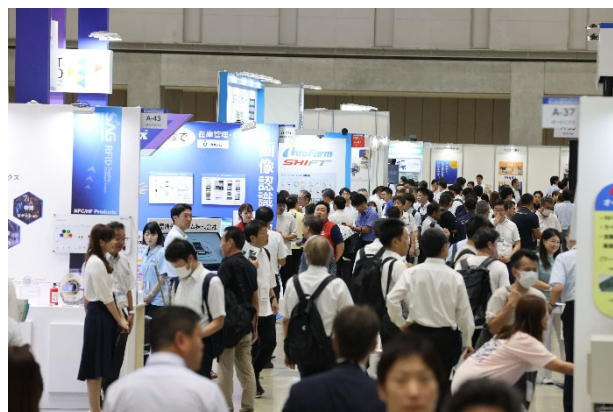

## **AUTO-ID COMMUNICATION EXPO PROFILE**

---

**The only exhibition in Japan devoted exclusively to cutting-edge automatic identification products, technologies and solutions.**

### **Exhibit Categories**

- Automatic identification products and technologies  
Bar codes and Two-dimensional symbols, GS1 DataBar, RFID, NFC, Cards (IC, magnetic, optical, etc.), OCR, Biometrics, Image recognition
- Solutions using automatic identification  
All solutions that take advantage of automatic identification, such as production support systems, distribution and logistics systems, retail and wholesale support systems, traceability, Supply Chain Management (SCM), event and amusement support systems, Customer Relationship Management (CRM), security systems, medical, education, library, transportation (rail, air, harbor, etc.), finance, disaster control, other public service support systems
- Middleware platform, encryption technologies, image processing

### **A zone combining AI with image recognition, the ultimate automatic recognition technology, is set up!**

- Imaging×AI Zone  
This zone consists of "object recognition," which outputs representative objects in images, "object detection," which identifies and locates objects in images, and "image caption," which outputs explanatory text for objects in images. Special feature on image recognition, which is the ultimate automatic recognition technology, such as "generation" and "segmentation" that identifies each pixel.

### **A merit to exhibit this Trade Show!**

- Automatic identification solutions can be offered to users.  
Many users from industries such as manufacturing, distribution, logistics, retailing, and public services will attend this exhibition seeking efficient, safe, and reliable automatic identification solutions.
- Many system integrators and vendors will attend, seeking cutting-edge equipment and technologies.  
Because many system integrators and related vendors will attend this exhibition, it will be a great opportunity to expand your business and sales channels.
- The exhibition will be a place for integration and collaboration with automatic identification related businesses.  
This exhibition will be a great opportunity for collaboration between businesses and the acquisition of business partners, as cutting-edge equipment and products, solutions, and services related to automatic identification will be exhibited under the same roof, and many system integrators and vendors will be attending



# AUTO-ID & COMMUNICATION EXPO 2025

## ~ A BRIGHTER FUTURE WITH AUTO-ID ~

### BOOTH SIZE AND CHARGES “Type A”

**Minimum booth Unit (size)** : 2.97m(W)×2.97m(D)×2.7m(H)

**Participation fee per minimum booth unit :**

| Number of booths  | Exhibition Fee (Cost per booth including consumption tax) |             |
|-------------------|---|-------------|
|                   | JAISA members   | Non-members |
| 1 to 2 booths     | 429,000 yen   | 484,000 yen |
| 3 to 7 booths     | 385,000 yen   | 440,000 yen |
| 8 to 12 booths    | 341,000 yen   | 396,000 yen |
| 13 to 15 booths   | 330,000 yen   | 385,000 yen |
| 16 to 24 booths   | 319,000 yen   | 374,000 yen |
| 25 booths or more | 297,000 yen   | 352,000 yen |

(JPY, Consumption tax included)

The exhibition fees include: exhibition space -- width: 2.97 m × depth 2.97 m -- walls

#### Explanation of Booth Layout

Layout of booths is to be chosen from alternatives shown on the below.

- Minimum 4 units of booth are required to form “Block” type layout.
- Minimum 8 units of booth are required to form “Island” type layout.
- The maximum number of booth allowed to form “Row” type layout is 5

1 to 5 booths in a Row type

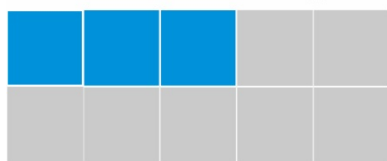

4 block type booths

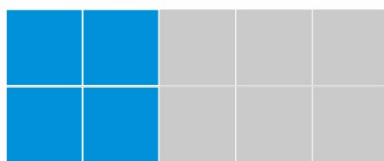

8 Island type booths

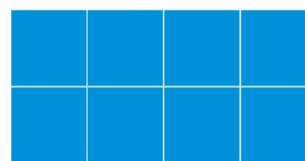

#### On height restrictions for decorations

##### \*Row type booth(s)

##### \*Block type booth(s)

Decorations are permitted to a maximum height of 2.7 m for areas within 1 m of adjacent booths, rear walls and access aisles, while the maximum height for any areas other than these is 4.0m.

##### \*Row type booth(s)

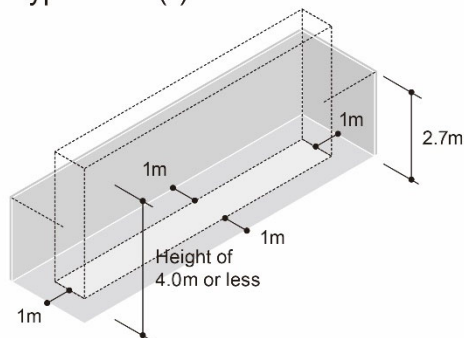

##### \*Block type booth(s)

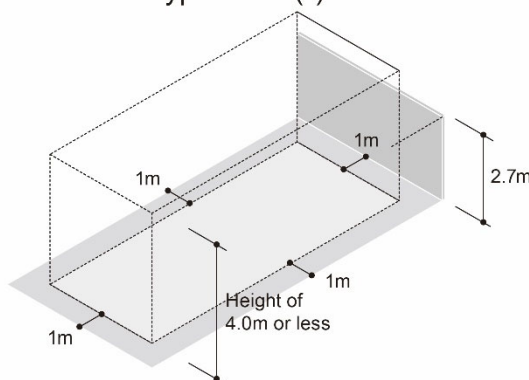

##### \*\* “Island” type booth(s)

Decoration is permitted up to a maximum height of 5.0m.



**BOOTH SIZE AND CHARGES “Type B (Low-priced, Small size)”**

**Minimum booth Unit (size) : 1.98m(W)×1.98m(D)×2.7m(H)**

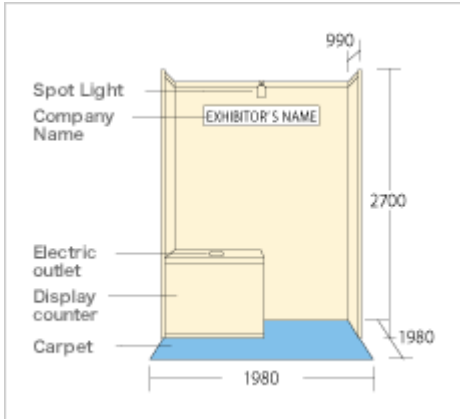

**Participation fee per minimum booth unit :**

| Number of booth | Exhibition Fee (Cost per booth including consumption tax) |                    |
|-----------------|---|--------------------|
|                 | JAISA Members:  | Non-JAISA Members: |
| 1 to 2 booths   | 231,000 yen   | 264,000 yen        |

The exhibition fees include:

exhibition space -- width: 1.98 m × depth 1.98 m -- walls (rear and side, 1 m); company nameplate; carpet;  
 exhibition stand--width: 0.99 m × depth 0.99 m × height: 0.77 m -- spotlight: 100W × 1; electrical outlets (100V with ground) —one set of two outlets; installation costs for electrical lines up to 500W; electricity costs.

\* Additional charges apply for requests of additional equipment. Detailed materials will be distributed at the orientation for exhibitors.

\* Please be aware that even when the basic display mentioned above is not used, deductions from the exhibition fee cannot be made.

**On height restrictions for decorations**

The maximum standard height is 2.7 m.

**Exhibition conditions**

- Up to two booths per company
- Cannot be exhibited together with Type A exhibition specifications
- Presentations using equipment such as microphones and speakers cannot be given in the booths.
- The locations of the booths are not determined by lottery, but rather at the discretion of the host.

# **AUTO-ID & COMMUNICATION EXPO 2025**

## **~ A BRIGHTER FUTURE WITH AUTO-ID ~**

### **Imaging × AI Zone**

---

## **A zone combining AI with image recognition, the ultimate automatic recognition technology, is set up!**

In recent years, AI has been actively introduced in various fields. Particularly in the realm of automatic recognition, image recognition utilizing AI has garnered significant attention.

The performance of AI-based image recognition has improved dramatically in recent years, leading to its application in a wide range of fields such as recognizing and translating text, preventing defective parts by visual inspection, medical image diagnosis, face authentication systems, unmanned cash registers, and automated driving. Its potential is expected to further grow in the future.

In the evolving field of image recognition, this zone will focus on image recognition equipment and technologies combined with AI solutions.

### **Exhibit Categories**

- **AI Solutions**

Object recognition (object classification), image analysis systems, object detection, anomaly detection, segmentation (region detection), image caption generation, and more.

- **Systems**

Face/fingerprint authentication systems, next-generation OCR systems (character recognition), augmented reality (AR) systems, image storage systems, spatial recognition systems, and more.

- **Software**

Inspection software, measurement software, analysis software, image compression software, and more.

- **Image Input Equipment/Devices**

Various cameras, image input boards, image sensors, lighting equipment for image input, and more.

- **Image Processing Equipment/Devices**

Various image processing devices, image analysis systems, image inspections, image processing boards, and more.

### **Target Attendees**

Departments responsible for equipment in industries such as manufacturing, distribution/retail, logistics, automotive, construction, security, nursing/welfare/medical, commercial facilities, building management, etc.

### **Exhibition fees and exhibition unit specifications**

Applied in accordance with type A or type B of the AUTO-ID & COMMUNICATION Expo.

# AUTO-ID & COMMUNICATION EXPO 2025

## ~ A BRIGHTER FUTURE WITH AUTO-ID ~

### HOW TO EXHIBIT

---

#### Application

Please fill in the attached “application form for exhibit” and send it to the Show Office.

#### Application Deadline

May 30, 2025

(The application will be closed as soon as all the booths are booked.)

#### Booth assignment

The booth assignment will be decided by open lot at exhibitor’s explanatory meeting on Beginning of July. If it is impossible to attend the meeting, the organizer draws lots instead of them.

#### Payment

On receipt of the application form, invoice will be issued by the Show Office.

Please make remittance in Japanese Yen to the designated bank account by June 23 (Mon.), 2025. In the event of the exhibitor failing to pay the participation fee by the deadline (June 23, 2025), an exhibition booth cannot be reserved.

The payment of the participation fee must be made in Japanese Yen, and all commissions concerning the bank transfer are also charged to the exhibitor.

#### Cancellation

As a principle, no cancellation is accepted. The organizer, however, may accept the cancellation if there should be right reason to accept with the following cancellation fee.

|                                      |   |                        |
|--------------------------------------|---|------------------------|
| June 1 (San.) - June 30 (Mon.), 2025 | : | 50% participation fee  |
| After July 1, 2025                   | : | 100% participation fee |

#### Schedule

|                       |  |
|-----------------------|--|
| May 30, 2025 (Fri.)   | Application for AUTO-ID & COMMUNICATION EXPO Deadline                |
| June 23, 2025 (Mon.)  | Remittance deadline  |
| Beginning of July     | Exhibitor’s explanatory meeting, Booth assignment open lot(in Tokyo) |
| Beginning of August   | Sending of the Invitation Tickets                                    |
| September 8 & 9, 2025 | Move-in / Set-up day   |
| September 12, 2025    | Move-out / Dismantle day   |



# AUTO-ID & COMMUNICATION EXPO 2025

## ~ A BRIGHTER FUTURE WITH AUTO-ID ~

### OFFICIAL ADVERTISEMENTS

#### Advertisements on the Official Site

We will post the AUTO-ID Communication Expo official website from the end of March to the end of October. A wealth of information is posted at the official website, including detailed information on the Expo and exhibit information from exhibitors, as well as numerous speeches every year from relevant people in the industry.

Please use the following advertising plan, which is set for the official site from this year going forward. The plan provides the opportunity for you to effectively promote your company prior to the time of the Expo in order to draw visitors to your booth.

You can run banner advertisements and menu bar advertisements at the official homepage for the 27th AUTOID Communication Expo.

#### 《Requirements for Application》

■Deadline for Application: July 18 (Fri), 2025

\* The application period ends if all time slots are filled

|  |              |  |
|--|--------------|--|
|  |              | Banner                                       |
| Image Size                               |              | 100 pixels (height) ×<br>230 pixels (length) |
| File Format                              | GIF          | ○  |
|  | Animated GIF | ○  |
| Fee for Posting /<br>per month(with tax) |              | 22,000 yen                                   |
| Number of Applications                   |              | 4  |
| Term of Posting                          |              | Scheduled for: 1 March 2025—31 October 2025  |



#### E-Mail News with Five-Column Ads

At AUTO-ID COMMUNICATION Expo, E-Mail News bulletins are scheduled to be sent multiple times to the mailing list (approximately 80,000 past Expo visitors.)

#### 《Requirements for Application》

■Deadline for application: Please refer to the figure to the below

\* The application period ends if all time slots are filled.

■Number of Applications: One for each mail.

■Method of Submission: As data

■Size of Draft: Body text (70 characters x five lines)

■Fee for posting: 33,000 yen (with tax)

| Time frame | Topics                                  | Time to send        | Deadline for applications |
|------------|---|---------------------|---------------------------|
| ①          | Latest Information Posted               | Beginning of August | June 13                   |
| ②          | A variety of events at the venue        | Middle of August    | July 25                   |
| ③          | Now accepting applications for seminars | late August         | July 25                   |
| ④          | Opening Next Week!                      | September 2         | July 25                   |
| ⑤          | Seminar Deadline Tomorrow               | September 4         | July 25                   |
| ⑥          | Opening Tomorrow                        | September 9         | July 25                   |
| ⑦          | Held until Tomorrow                     | September 11        | July 25                   |

## ADMINISTRATION

---

The following facilities will be provided at the show site for the convenience of exhibitors and visitors as well as for the management of the show.

**Secretariat Office** The Secretariat office will be set up at the show site from 8:00 , September 9 (Mon) to 22:00, September 13 (Fri).

TOKYO BIG SIGHT(Tokyo International Exhibition Center), West Hall  
3-11-1, Koto-ku, Ariake, Tokyo 135-0063 Japan  
Secretariat of 「AUTO-ID & COMMUNICATION EXPO 2025」

### Registration Counter

The Registration Counter will be set up in front of the exhibition site, where visitor registration and information service will be rendered.

### Lounge

Lounge will be provided inside the exhibition site as a space for exhibitors to have business talks with visitors.

### Prepaid card for Restaurants

Prepaid card system is available at the exhibition site. Instead of cash payment, you can use the prepaid card at the restaurants. The prepaid card is sold at the 「Service corner」at TOKYO BIG SIGHT Entrance Hall 2F.

### Facilities of the Exhibition Hall

West Hall

|                       |   |
|-----------------------|---|
| Hall Illuminance      | : 500 lux                                   |
| Ceiling height        | : 12m                                       |
| Air-conditioning      | : Available                                 |
| Floor load            | : 5t/m <sup>2</sup>                         |
| Cargo entrance        | : H4.1-6.0m×W7.4m                           |
| Meeting rooms         | : We will set up inside the exhibition Hall |
| Restaurants and shops | : About 20 shops                            |

# **AUTO-ID & COMMUNICATION EXPO 2025**

## **~ A BRIGHTER FUTURE WITH AUTO-ID ~**

### **REPORT OF LAST EXHIBITION**

---

#### **AUTO-ID & COMMUNICATION EXPO 2024**

Show Period : September 11 (Wed) - 13 (Fri), 2024 10:00-17:00  
Venue : TOKYO BIG SIGHT(Tokyo International Exhibition Center) West Hall 4  
Number of Exhibitors and Booths : 78 corporations and organization, at 174 booths  
Total Number of Visitors : 13,699  
Admission Fee : FREE (pre-registration required)  
Sponsor : Japan Automatic Identification Systems Association (JAISA)  
Supporting Organizations : Ministry of Internal Affairs and Communication  
Ministry of Foreign Affairs  
Ministry of Economy, Trade and Industry  
Special Cooperation : SANKEI SHIMBUN CO.,LTD.  
Cooperating Organization : Approx.30 relevant organizations  
Seminar : AUID-ID Seminar, Business & Technology SPICE  
September 11 (Wed) - 13 (Fri)

#### Exhibitors List 2024

##### **AUTOID & COMMUNICATION EXPO**

AIMEX Corp. | AINIX CO. | Almarq Inc. | Asahi Rubber Inc. | Asterisk Inc. | Autonics Co., Ltd. | BUSICOM Co., Ltd. | Cleantech and Beyond Co., Ltd. | CLI, Inc. | CRYSTONE | CSE Co., Ltd. | DAIDO CORP. | DENSO WAVE INC. | Fujikura Dia Cable Ltd. | Gazo Co., Ltd. | GENERAL CO., LTD. | GIGA-TMS Inc. | GS1 Japan | HAYATO Information Co., Ltd. | ICOP I.T.G. Inc. | Imager Co., Ltd. | INCOM CO.,LTD. | JAPAN INDUSTRIAL PUBLISHING CO., LTD. | KISCO LTD. / Spotag Electronics (Jiangsu) Co.,Ltd. | Kobayashi Create Co., Ltd. | MARS TOHKEN SOLUTION CO. LTD. | MASPRO DENKOH CORP. | Microwave Absorbers Inc. | Midoriya Information Systems Co., Ltd | Minerva Luxury Linens & Home Style Co., Ltd. / Minerva Co., Ltd. | M-RF Co.,LTD / PHYCHIPS INC | NEC Platforms, Ltd. | NIHON MICRON Co., Ltd. | NIKKEI INC. | Nissei Limited | NITTA CORP. | Okabe Marking Systems Co., Ltd. / AVNET K.K. | Ondemand Laboratory Co., Ltd. | Penetrate of Limits Co.,LTD. | PHOENIX CO., LTD | RFID Alliance Corp. / Alien Technology / Datamars / Rfcamp | RFinCharge Co., Ltd. | RICHRFID Japan Co.,Ltd. | Ricoh Co., Ltd. | Riotec Co., Ltd. | RYUKEN CO., LTD. | RYUTU JOHO RABERUSHA | SAG Japan Co, LTD | SATO CORP. | SEKISUI JUSHI CORP. | SilenceNet, Inc. | Smart Solution Technology Inc. | TAKAYA Corp. | TAKETOMO, INC. | Techsor Inc. | Terrara Code Research Institute Inc. | TOPPAN Digital Inc. | TOSHIBA TEC CORP. | VECKS Inc.

##### **Imaging × AI Zone**

BizTech, Inc. | FastLabel inc. | GRAPE SYSTEMS INC. | SHIFT Ltd. / Info Farm co., Ltd | SiriusVision CO., LTD. | Soliton Systems K.K. | TOME R&D Inc. | Trust Technology Co., Ltd.

##### **Poster Catalog Corner**

Duplo Co., Ltd. | IDEC AUTO-ID SOLUTIONS Corp. | SATO CORP. | SYSTEMDATAKIKI CO.,LTD